

SP 02

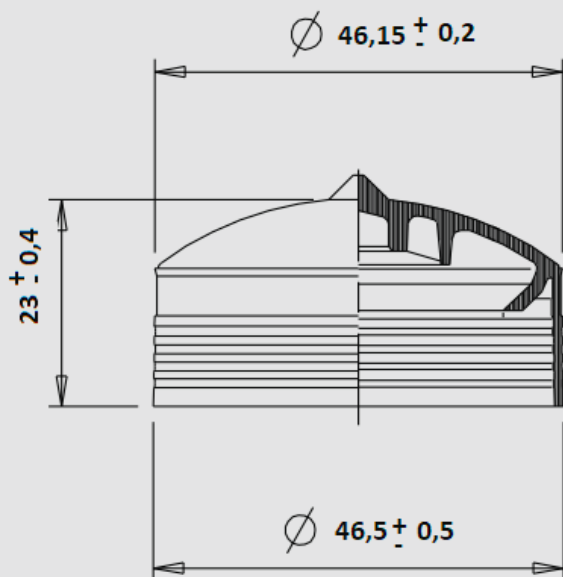

SPECIFICATIONS:

Article Code : SP 02

Reference : 320.000

Material : HDPE

Volume : -

Weight : 5,8 g

Packaging Qty : 1,750 pcs

All dimensions and tolerances are subject to technical changes.
For dimensions which do not have tolerances, DIN 16742 standard can be used as a reference.
Our product recommendations are based on our own knowledge and experiences and can not replace the customer's own tests and confirmations.

